

# RE 35 Ø35 mm, Graphite Brushes, 90 Watt

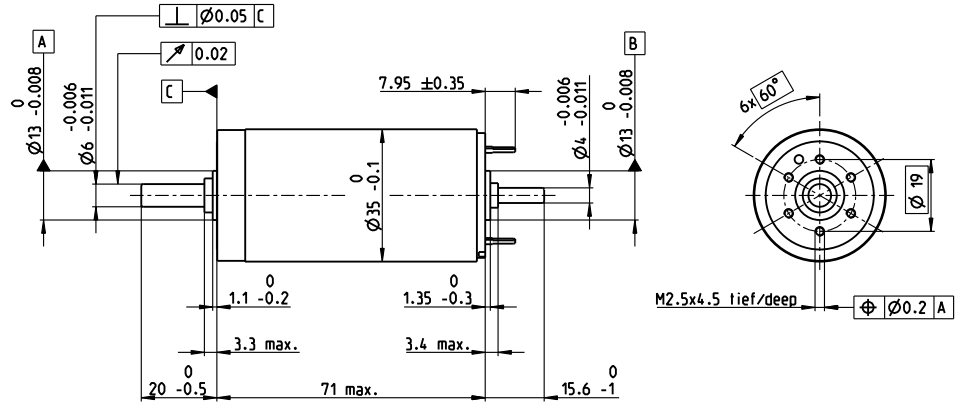
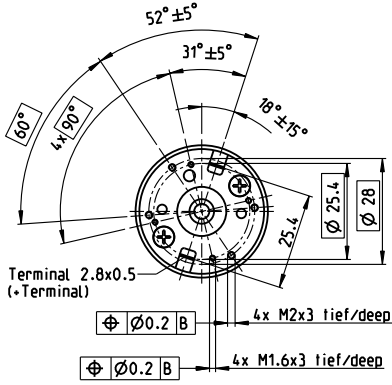

## M 1:2

- Stock program
- Standard program
- Special program (on request)

Part Numbers													
according to dimensional drawing shaft length 15.6 shortened to 4 mm													
273752	323890	273753	273754	273755	273756	273757	273758	273759	273760	273761	273762	273763	
285785	323891	285786	285787	285788	285789	285790	285791	285792	285793	285794	285795	285796	

Motor Data																			
<b>Values at nominal voltage</b>																			
1 Nominal voltage	V	15	24	30	42	48	48	48	48	48	48	48	48	48	48	48	48		
2 No load speed	rpm	7200	7750	7280	7580	7310	6680	5990	4770	3830	3150	2590	2110	1630					
3 No load current	mA	188	128	94.1	70.5	58.9	52.6	46	34.9	27	21.6	17.3	13.9	10.5					
4 Nominal speed	rpm	6500	6990	6470	6800	6510	5870	5170	3930	2990	2290	1720	1230	737					
5 Nominal torque (max. continuous torque)	mNm	74.2	105	101	105	103	104	104	106	108	107	107	106	106					
6 Nominal current (max. continuous current)	A	4	3.72	2.68	2.07	1.71	1.58	1.41	1.15	0.934	0.764	0.628	0.508	0.393					
7 Stall torque	mNm	931	1200	976	1090	983	892	778	621	499	399	323	256	196					
8 Stall current	A	47.9	41.2	25.1	20.7	15.8	13.1	10.3	6.52	4.21	2.77	1.85	1.2	0.71					
9 Max. efficiency	%	85	87	87	88	88	87	86	85	84	83	81	79	77					
<b>Characteristics</b>																			
10 Terminal resistance	Ω	0.313	0.582	1.2	2.03	3.04	3.66	4.68	7.36	11.4	17.3	26	40.1	67.6					
11 Terminal inductance	mH	0.085	0.191	0.34	0.62	0.87	1.04	1.29	2.04	3.16	4.65	6.89	10.3	17.1					
12 Torque constant	mNm/A	19.4	29.2	38.9	52.5	62.2	68	75.8	95.2	119	144	175	214	276					
13 Speed constant	rpm/V	491	328	246	182	154	140	126	100	80.5	66.4	54.6	44.7	34.6					
14 Speed / torque gradient	rpm/mNm	7.91	6.54	7.55	7.03	7.5	7.55	7.77	7.75	7.74	7.99	8.1	8.38	8.47					
15 Mechanical time constant	ms	5.62	5.41	5.37	5.32	5.32	5.32	5.33	5.33	5.33	5.34	5.35	5.36	5.38					
16 Rotor inertia	gcm <sup>2</sup>	67.9	79	67.9	72.3	67.7	67.2	65.4	65.7	65.7	63.8	63	61	60.6					

Specifications	
<b>Thermal data</b>	
17 Thermal resistance housing-ambient	6.2 K/W
18 Thermal resistance winding-housing	2 K/W
19 Thermal time constant winding	30.1 s
20 Thermal time constant motor	707 s
21 Ambient temperature	-30...+100°C
22 Max. winding temperature	+155°C
<b>Mechanical data (ball bearings)</b>	
23 Max. speed	12000 rpm
24 Axial play	0.05 - 0.15 mm
25 Radial play	0.025 mm
26 Max. axial load (dynamic)	5.6 N
27 Max. force for press fits (static) (static, shaft supported)	110 N
28 Max. radial load, 5 mm from flange	1200 N
	28 N

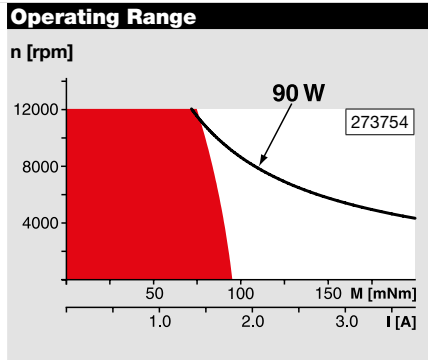

**Comments**

**Continuous operation**  
In observation of above listed thermal resistance (lines 17 and 18) the maximum permissible winding temperature will be reached during continuous operation at 25°C ambient.  
= Thermal limit.

**Short term operation**  
The motor may be briefly overloaded (recurring).

**Assigned power rating**

Other specifications	
29 Number of pole pairs	1
30 Number of commutator segments	13
31 Weight of motor	340 g

Values listed in the table are nominal.  
Explanation of the figures on page 64.

**Option**  
Hollow shaft as special design  
Preloaded ball bearings

**maxon Modular System** Overview on page 28–36

<p><b>Planetary Gearhead</b> Ø32 mm 0.75 - 6.0 Nm Page 342–349</p> <p><b>Planetary Gearhead</b> Ø32 mm 4.0 - 8.0 Nm Page 350</p> <p><b>Planetary Gearhead</b> Ø42 mm 3 - 15 Nm Page 354</p> <p><b>Screw Drive</b> Ø32 mm Page 374–378</p>		<p><b>Recommended Electronics:</b> <b>Notes</b> Page 30</p> <p>ESCON Mod. 50/5 445</p> <p>ESCON 50/5 447</p> <p>EPOS4 50/5 453</p> <p>EPOS4 Mod./Comp. 50/5 453</p> <p>EPOS2 P 24/5 464</p> <p>MAXPOS 50/5 468</p>	<p><b>Encoder MR</b> 256 - 1024 CPT, 3 channels Page 420</p> <p><b>Encoder HED_ 5540</b> 500 CPT, 3 channels Page 429/431</p> <p><b>DC-Tacho DCT</b> Ø22 mm 0.52 V Page 438</p> <p><b>Brake AB 28</b> 24 VDC 0.4 Nm Page 480</p> <p><b>End cap</b> Page 485</p>
---	--	--	---